

No 034501

A-FTF-J-NFB

MECHANICAL ENGINEERING

Paper II

(Conventional)

Time Allowed : Three Hours

Maximum Marks : 200

INSTRUCTIONS

Candidates should attempt Question No. 1 in Section A which is compulsory, TWO questions from Section B and TWO questions from Section C.

Question No. 1 is of short answer type.

The number of marks carried by each subdivision of a question is indicated at the end of the subdivision/question.

Answers must be written in ENGLISH.

Assume suitable data, if necessary and indicate the same clearly.

Wherever a question is attempted, all its subdivisions must be attempted.

Unless otherwise indicated, symbols and notations used have their usual meanings.

Neat sketches to be drawn, wherever required.

SECTION A

1. (a) A balance mass of value $\frac{2}{3}m$ is placed diametrically opposite to the crank at crank radius r . What is the expression for the unbalanced force along the line of stroke of a reciprocating engine for angular position θ of the crank with respect to the line of stroke ?
- (b) (i) What is an isochronous governor ?
(ii) State the phenomenon of hunting in a spring controlled governor.
- (c) (i) Explain briefly vibration isolation and transmissibility.
(ii) The natural frequency of a system put on a foundation is ω_n . The operating frequency is ω . What is the minimum value of $\left(\frac{\omega}{\omega_n}\right)$ beyond which the vibration isolation is possible or meaningful ?
- (d) The Mohr's circle for a plane stress is a circle of radius R with its origin at $+2R$ on σ axis. Sketch the Mohr's circle and determine σ_{\max} , σ_{\min} , σ_{av} , $(\tau_{xy})_{\max}$ for this situation.
- (e) Briefly explain the role of idle gears in a simple gear train, with the help of neat sketches.
- (f) List two temporary fasteners and explain the working of one of these.

- (g) The state of stress at a point in a loaded machine member is given by the principal stresses $\sigma_1 = 600 \text{ MPa}$, $\sigma_2 = 0$ and $\sigma_3 = -600 \text{ MPa}$.
- (i) What is the magnitude of the maximum shear stress ?
 - (ii) What is the inclination of the plane on which the maximum shear stress acts with respect to the plane on which the maximum principal stress σ_1 acts ?
- (h) Two long columns are made of identical lengths ' l ' and flexural rigidities ' EI '. Column 1 is hinged at both ends whereas for column 2 one end is fixed and the other end is free.
- (i) Write the expression for Euler's buckling load for column 1.
 - (ii) What is the ratio of Euler's buckling load of column 1 to that of column 2 ?
- (i) A close coiled helical spring made of wire diameter d has mean coil radius R , number of turns n and modulus of rigidity G . The spring is subjected to an axial compression W .
- (1) Write the expression for the stiffness of the spring.
 - (2) What is the magnitude of the maximum shear stress induced in the spring wire neglecting the curvature effect ?

- (j) List the conditions under which a rope drive is preferred to a belt drive.
- (k) What is achieved by using a metallic single crystal casting ? Give one application of a single crystal casting made of wasp alloy.
- (l) In investment casting process two types of ceramic slurries are used. Why do we use them and in what sequence are they applied ?
- (m) What is the shape of a runner for making a sand mould ? On what considerations is this shape selected ?
- (n) What does the following marking on a grinding wheel denote ?

55 - C - 36 - D - 9 - S - 28

- (o) Show crater wear and flank wear on a single point cutting tool. State the factors responsible for wear on a turning tool.
- (p) Compare the drilling and boring operations in relation to cutting action, accuracy and applications.
- (q) What is the effect on order quantity when the demand increases by four-fold in basic order point inventory system and other factors remain unchanged ? Explain.

- (r) A company is faced with a situation where it can either produce some item by adding additional infrastructure which will cost them Rs. 15,00,000/- but unit cost of production will be Rs. 5/- each. Alternatively it can buy the same item from a vendor at a rate of Rs. 20/- each. When should the company add to its capacity in terms of demand of items per annum ? Draw the diagram to show the BEP.
- (s) Define the term 'standard time' and list the common allowances given in work standard.
- (t) Pointers are commonly used in 'C' for creating linked lists. Write a FORTRAN code to implement pointers, that is, to traverse the linked list. 2×20=40

SECTION B

2. (a) A cantilever of circular solid cross-section is fixed at one end and carries a concentrated load P at the free end. The diameter at the free end is 200 mm and increases uniformly to 400 mm at the fixed end over a length of 2 m. At what distance from the free end will the bending stresses in the cantilever be maximum? Also calculate the value of the maximum bending stress if the concentrated load $P = 30$ kN.

15

(b) In a torsion test, the specimen is a hollow shaft with 50 mm external and 30 mm internal diameter. An applied torque of 1.6 kN-m is found to produce an angular twist of 0.4° measured on a length of 0.2 m of the shaft. The Young's modulus of elasticity obtained from a tensile test has been found to be 200 GPa. Find the values of

(i) Modulus of rigidity,

(ii) Poisson's ratio.

10

(c) A cylindrical shell has the following dimensions :

Length = 3 m

Inside diameter = 1 m

Thickness of metal = 10 mm

Internal pressure = 1.5 MPa

Calculate the change in dimensions of the shell and the maximum intensity of shear stress induced. Take $E = 200$ GPa and Poisson's ratio = $\nu = 0.3$.

15

3. (a) (i) Explain the term 'Interference' in involute gears and how this can be avoided. 2
- (ii) Derive the expression for minimum number of teeth on a pinion for Involute Rack to avoid interference. 8
- (iii) Find the minimum number of teeth on the pinion to avoid interference when the addendum for stub teeth is 0.84 module and the pressure angle $\phi = \cos^{-1} 0.95$, if (a) the gear ratio is 3 to 1 and (b) the pinion meshes with a rack. 10

(b) A vertical single cylinder is shown in Figure 3(b). The lower piston is connected to the centre crank. The stroke is 80 mm for the lower piston. The upper piston operates the two outer cranks which are at 180° to the centre crank.

The reciprocating parts for the lower piston weigh 10 kg.

The reciprocating parts for the upper piston weigh 20 kg.

Find the stroke of the upper piston when the primary force is balanced.

20

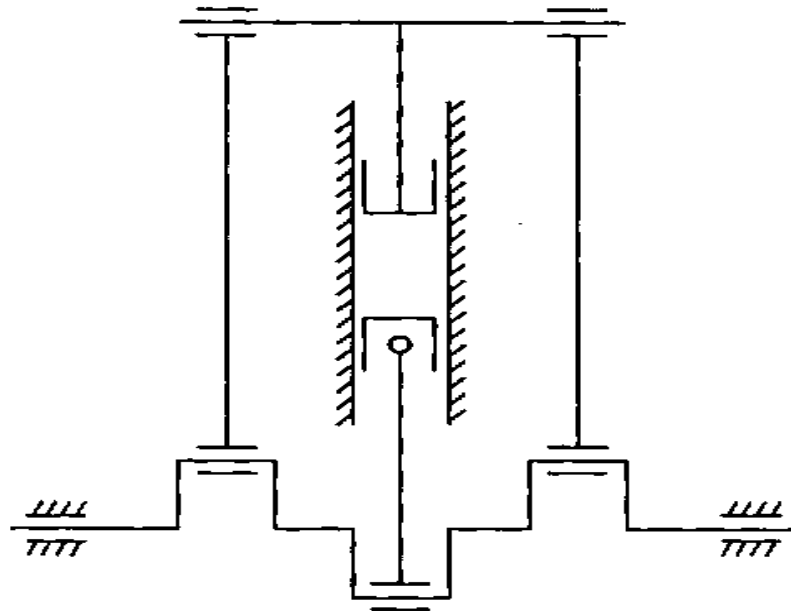

Figure 3(b)

4. (a) The screw of a car lift has 150 mm dia. with square threads of 50 mm pitch and lead of 100 mm. Assume 1000 N is required for lifting of the car and thread friction coefficient is 0.20.

(i) Compute the torques required to rotate the screw to raise the car and lower the car. Also compute the overall efficiency of the screw.

(ii) What is the flaw in the above design ?

15

- (b) A simple gear train consists of three gears with 18, 16 and 72 teeth. The 18 teeth pinion is connected to a 4 kW electric motor running at 2400 rpm. Design the shaft for 72 teeth gear if the shearing stress is not to exceed 60 MPa in the shaft.

15

- (c) Find the equivalent spring constant if the below shown spring systems are replaced by a single spring.

5

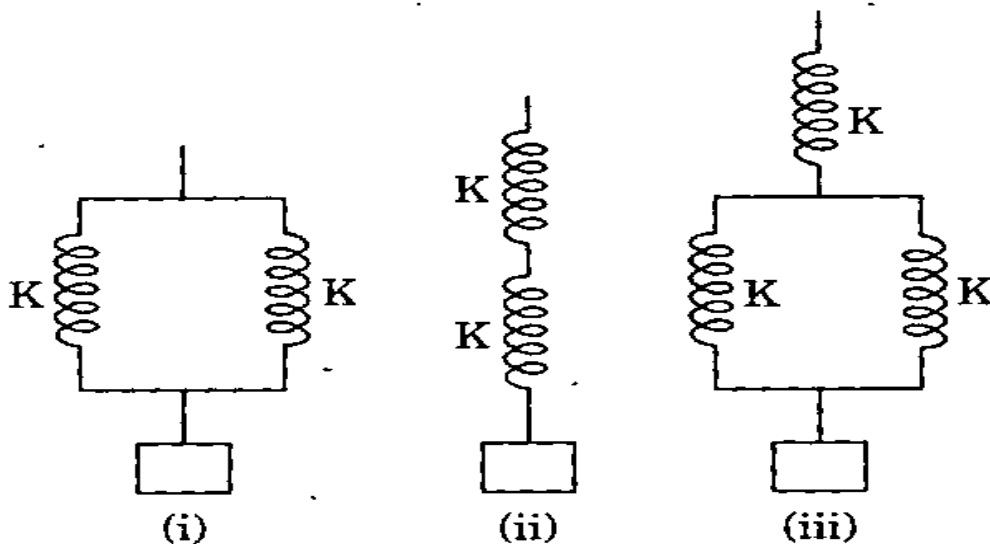

- (d) Most of the times the rotating disc-shafts have keys; under such conditions it cannot be assumed that the shaft has a uniform cross-section. For such a disc-shaft system how will you determine the limits of speed for instability?

5

SECTION C

5. (a) Explain the three types of oxy-acetylene flames. Indicate with the help of sketches the various zones, respective temperature ranges and applications of each type of flame. 20
- (b) Explain the processes of extrusion given below. Indicate one typical product made through each of these processes : 20
- (i) Direct Extrusion.
 - (ii) Indirect Extrusion
 - (iii) Hydrostatic Extrusion
 - (iv) Impact Extrusion

6. (a) Determine the optimum cutting speed for an operation on a lathe machine using the following information :

Tool change time	3 min
Tool regrind time	3 min
Machine running cost	Re. 0.50 per min
Depreciation of tool regrind	Rs. 5.0

The constants in the tool life equation are 60 and 0.2. 10

- (b) (i) Why are the alignment tests done on machine tools ?
- (ii) Give the list of common testing equipment needed for alignment tests on a general purpose lathe.
- (iii) Write steps to check straightness of carriage in a horizontal plane with the help of sketches. 15

- (c) (i) What is the principle of metal removal in EDM process ?
- (ii) Describe the process with the help of sketch.
- (iii) List advantages and limitations of the system.

15

7. (a) (i) List common time-series forecasting models. Explain simple exponential smoothing method of forecasting demand. What are its limitations ?
- (ii) The monthly forecast and demand values of a firm are given below :

Month	Forecast units	Demand units
Jan	100	97
Feb	100	93
Mar	100	110
Apr	100	98
May	102	130
Jun	104	133
Jul	106	129
Aug	108	138
Sep	110	136
Oct	112	124
Nov	114	139
Dec	116	125

Calculate Tracking Signal for each month.
Comment on the forecast model.

10

- (b) Four technicians are required to do four different jobs. Estimates of time to complete every job as provided by the technicians are as below :

Technician	Hours to Complete Job			
	Job 1	Job 2	Job 3	Job 4
A	20	36	31	27
B	24	34	45	22
C	22	45	38	18
D	37	40	35	28

Assign the jobs to technicians to minimize the total work-time. State the steps taken in the algorithm used.

15

- (c) Prepare a flow chart and write a program in FORTRAN for the following problem :

The cutting tool life (T) for machining operation is given by Taylor's equation $vT^n = C$ where v is the cutting speed and C, n are constants. An MS workpiece of 50 mm dia. is turned with a carbide tool with $n = 0.10$ and $C = 150$. It is proposed to study the variation of tool life with the rpm of the workpiece at which turning is performed. Assume that the speed of spindle of lathe can be varied from 100 rpm to 2000 rpm in the steps of 100 rpm.

15